

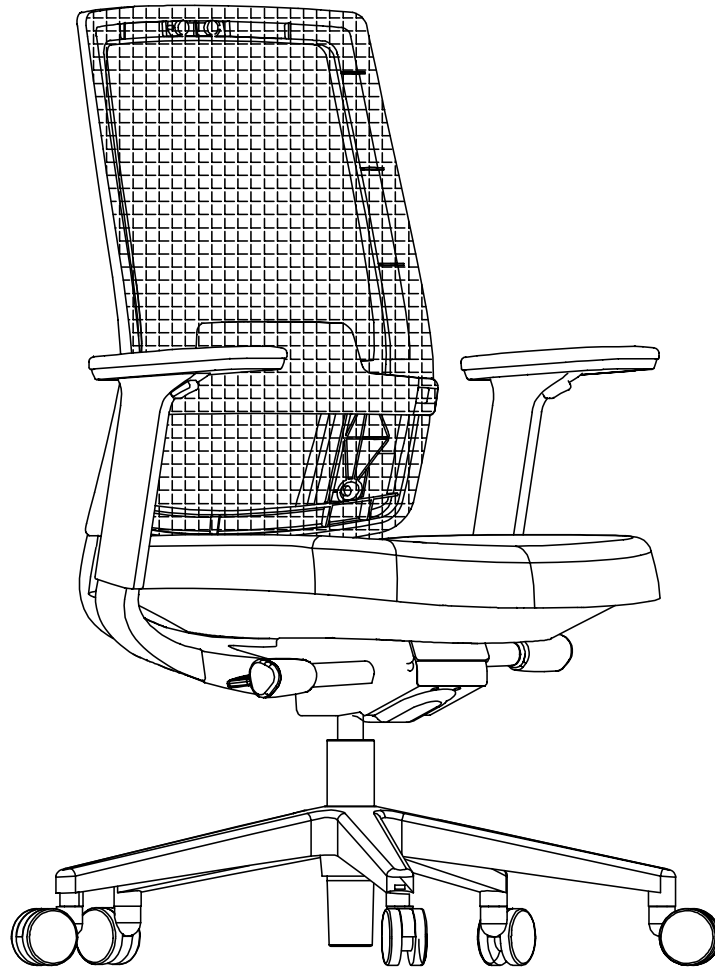

SCAN HERE
to see additional
information and
product videos



Tools Required

Allen key provided.
No additional tools required.

Parts Included

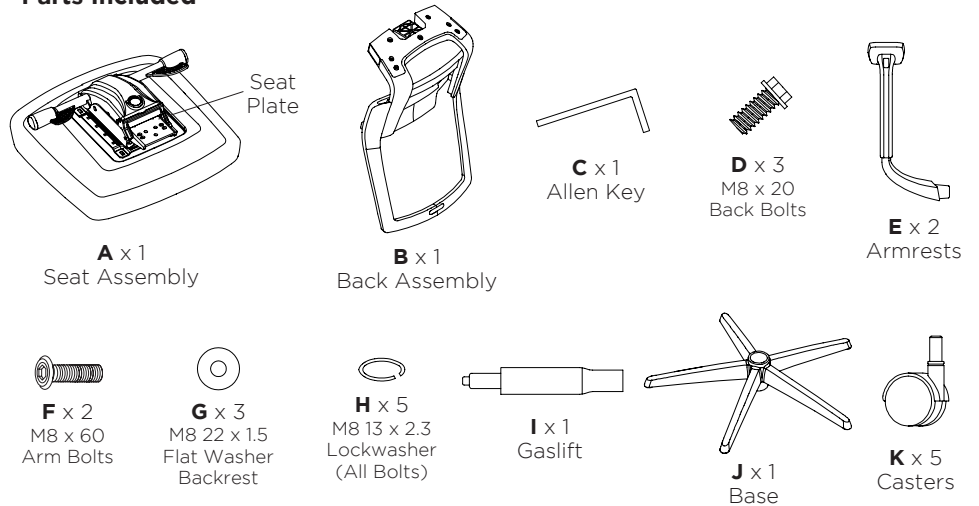

Optional Headrest

Step 1

Attach the seat plate so that the front of the plate matches the front label. Tighten screws using Allen Key. Attach back assembly to seat assembly by inserting screws.

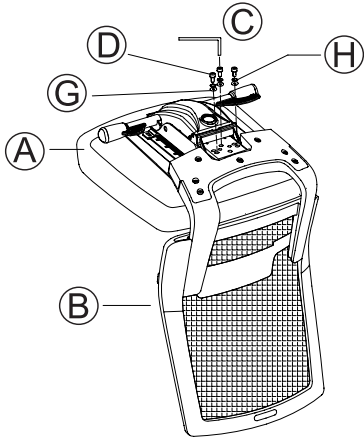

Step 2

Attach armrests (E) to seat assembly and tighten screws.

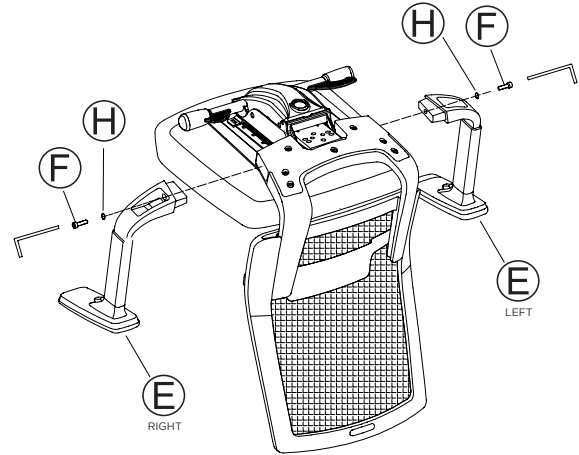

Step 3

Turn base (J) upside down. Press casters (K) into holes. Turn base upright and insert gas lift (I).

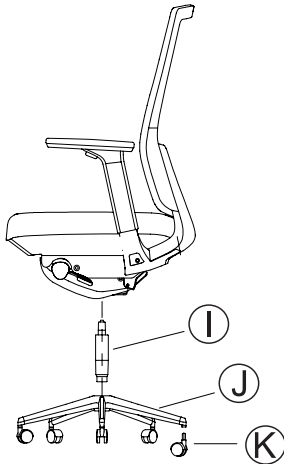

Step 4

Attach assembled chair to base. Press down firmly to attach.

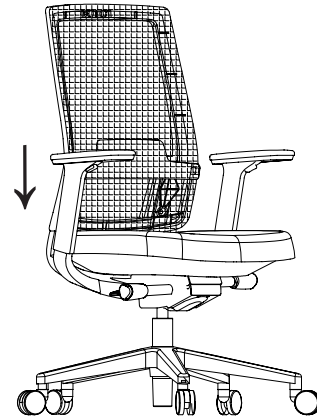

Step 5: Optional Headrest

Remove the Icon filler cover at the top of the backrest. (N). Install the headrest using the 2 screws (M) and tighten with the provided allen key.

